

ALKALINE-MANGANESE DIOXIDE BATTERY

Din forhandler



GACELL A/S - Sletten 17 - DK 7500 Holstebro - 961 02 961



Size: C (LR14) PX1400

KEY FEATURES

- Reliable Performance
- Excellent resistance to corrosion
- Designed to meet all major quality, safety and environmental standards:
 - Safety: IEC 60086-5
 - ANSI C 18.1M, Part-2
 - EU Battery Directive
 - Quality: ISO 14001 and 9001, Duracell World Class Continuous Improvement Program

TYPICAL APPLICATIONS

- Sanitizer Dispensers
- Air Fresheners
- Paper Towel Dispensers
- Flashlights
- Soap Dispensers

PROCELL®

PROFESSIONAL BATTERIES

Procell Professional batteries
Berkshire Corporate Park
Phone: 1-800-544-5454 (Toll-free)
www.procell.com

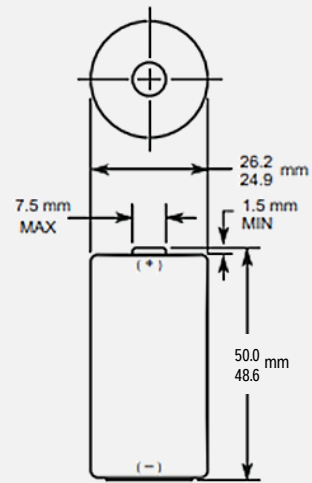

Dimensions shown are IEC standards

ELECTRICAL CHARACTERISTICS

- Nominal capacity (25 mA Cont., .8V cut-off) 8,240 mAh
- Typical Voltage (at + 20 °C) 1.5 V
- AC Impedance @ 1kHz 74 mΩ

PHYSICAL CHARACTERISTICS

- Typical weight 65.0 g (2.5 oz)
- Typical volume 26.9 cm³ (1.6 in³)
- Terminals Flat

OPERATING & STORAGE CONDITIONS

- Operating temperature range -20°C to 54°C (-4°F to 130°F)
- Recommended Storage (storage area should be clean, cool, dry and ventilated) 5°C to 30°C (41°F to 86°F)

Delivered capacity is dependent on the applied load, operating temperature and cut-off voltage. Please refer to the charts and discharge data shown for examples of the energy/service life that the battery will provide for various load conditions.

This data is subject to change. Performance information is typical. Contact Duracell for the latest information.

TYPICAL PERFORMANCE

Constant Current

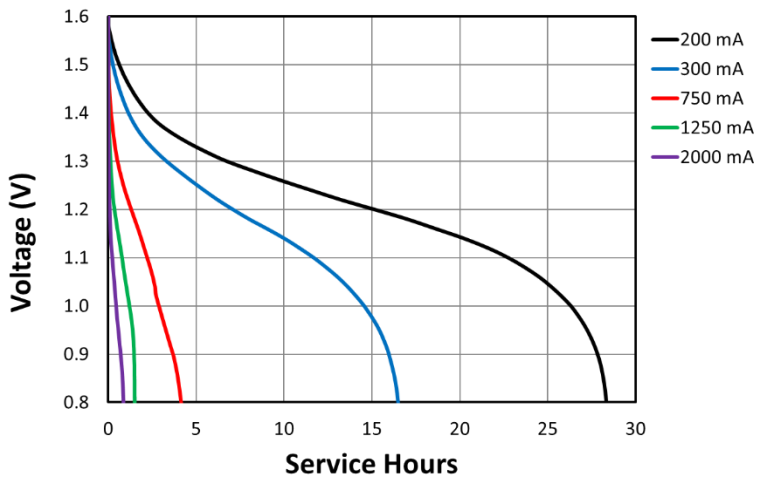

Constant Resistance

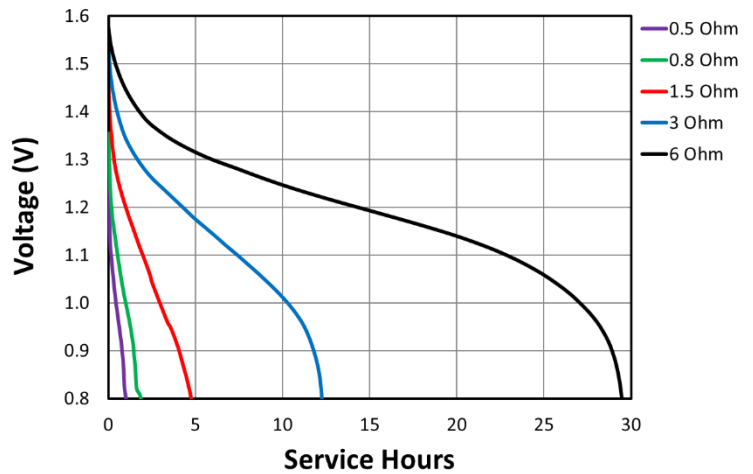

Constant Power

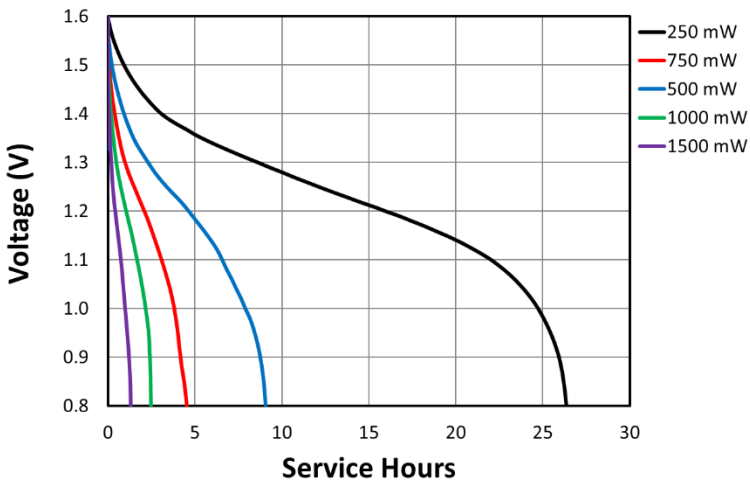

Constant Current - 200 mA

