

# Datenblatt – F05 08 145

## Blockbatterie Nass, wartungsarm

### Performance

Nennspannung:	8V
Nennkapazität C5:	145 Ah
Nennkapazität C20:	170 Ah
Kapazitätsreserven 25A:	295 min
Kapazitätsreserven 75A:	117 min
Elektrolyt:	Nass
Gehäusematerial:	PP
Separator:	Mikroporöser Blattseparator
Batteriegewicht (+/- 5 %):	29,2 kg

Gehäuse:	GC8
Länge:	260 mm
Breite:	180 mm
Höhe:	279 mm
Polausführung:	UTLM8

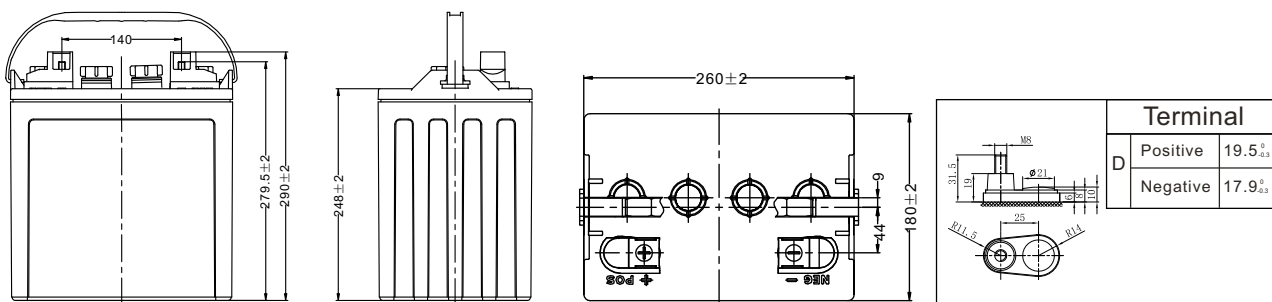

### Ladekurve

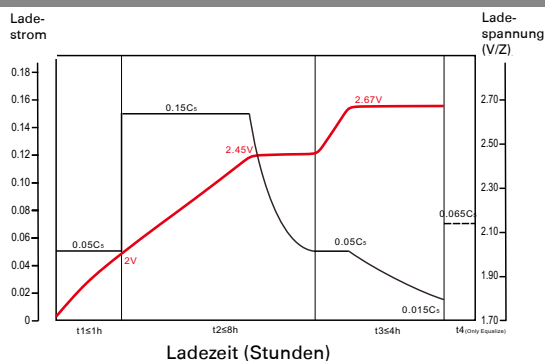

### Entladekurve

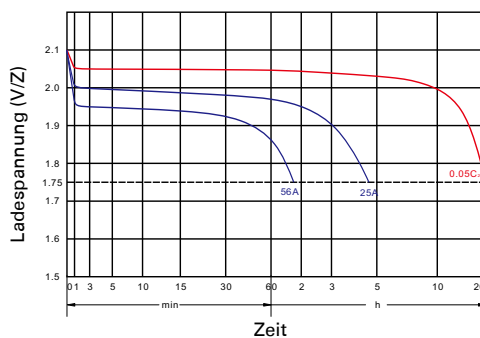

## ▶ Data sheet – F05 08 145

### Block battery flooded, low maintenance

#### Performance

Nominal voltage:	8V
Nominal capacity C5:	145 Ah
Nominal capacity C20:	170 Ah
Capacity reserves 25A:	295 min
Capacity reserves 75A:	117 min
Electrolyte:	Flooded
Housing material:	PP
Separator:	Microporous blade separator
Battery weight (+/- 5 %):	29.2 kg

Housing:	GC8
Length:	260 mm
Width:	180 mm
Height:	279 mm
Pole version:	UTL-M8

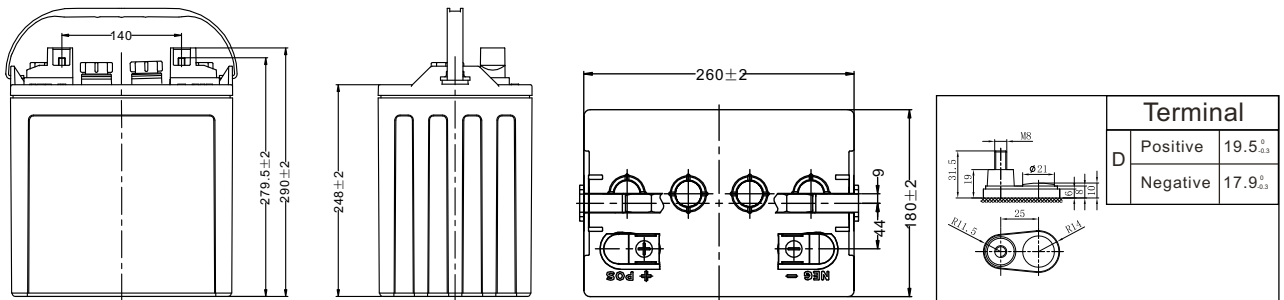

#### Charging Characteristics

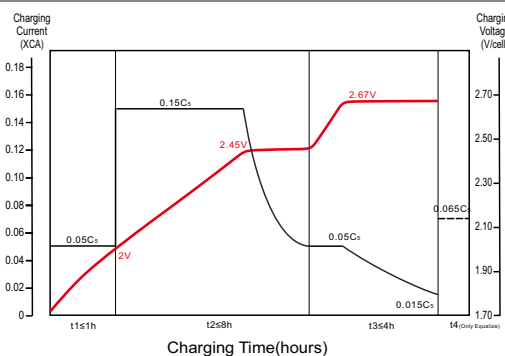

#### Discharge Characteristics

