

Datenblatt – F05 06 344

Blockbatterie Nass, wartungsarm

Performance

Nennspannung:	6V
Nennkapazität C5:	344 Ah
Nennkapazität C20:	420 Ah
Kapazitätsreserven 25A:	850 min
Kapazitätsreserven 75A:	220 min
Elektrolyt:	Nass
Gehäusematerial:	PP
Separator:	Mikroporöser Blattseparator
Batteriegewicht (+/- 5 %):	52 kg

Gehäuse:	BCI 903
Länge:	296 mm
Breite:	176 mm
Höhe:	425 mm
Polausführung:	DT-5/16

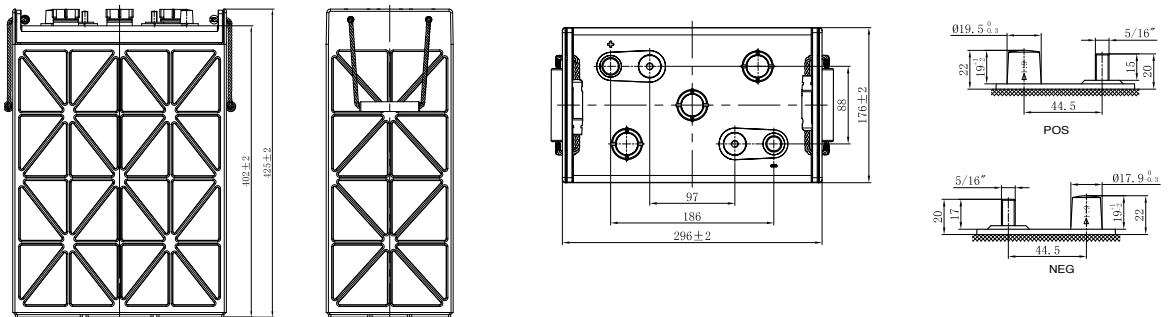

Ladekurve

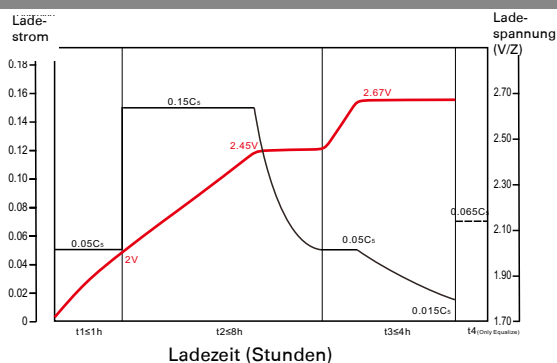

Entladekurve

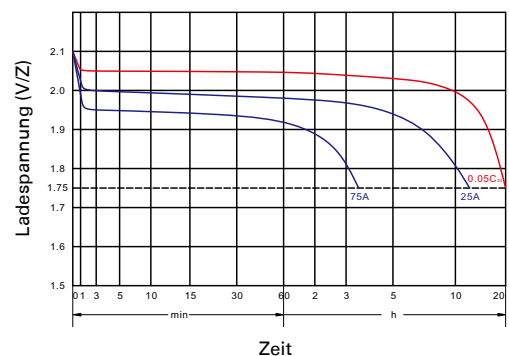

Data sheet – F05 06 344

Block battery flooded, low maintenance

Performance

Nominal voltage:	6V
Nominal capacity C5:	344 Ah
Nominal capacity C20:	420 Ah
Capacity reserves 25A:	850 min
Capacity reserves 75A:	220 min
Electrolyte:	Flooded
Housing material:	PP
Separator:	Microporous blade separator
Battery weight (+/- 5 %):	52 kg

Housing:	BCI 903
Length:	296 mm
Width:	176 mm
Height:	425 mm
Pole version:	DT-5/16

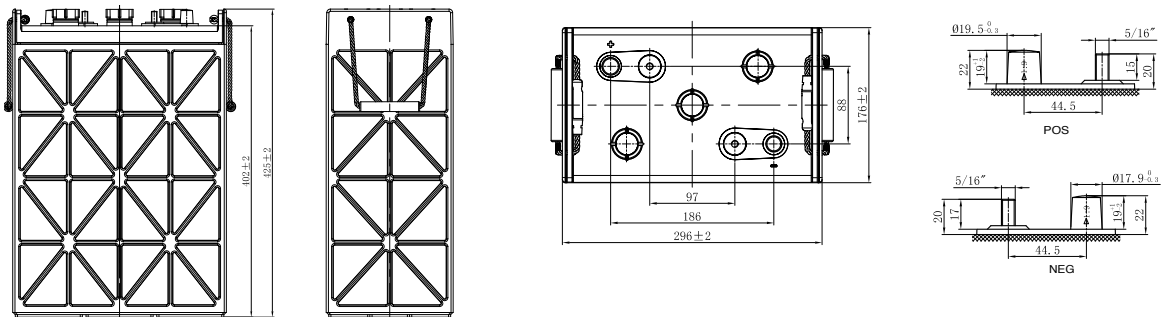

Charging Characteristics

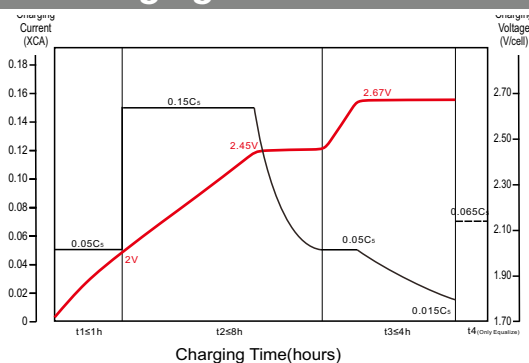

Discharge Characteristics

